

İÇİNDEKİLER / INDEX / INDICE

Giriş gücü ve servis faktörü / *Eingangsleistung und Betriebsfaktor* / Potenza entrata e fattore di servizio

2

Dişli Ünitesini Seçme / *Auswahl der Getriebe* / Selezione riduttore

3-4

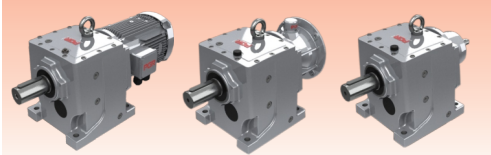

PA

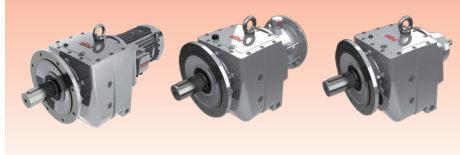

PF

5-7

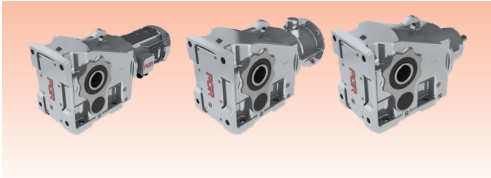

Ayaktan montajlı
Montierung mit Fussgehäuse
Montaggio con piedi

PKD

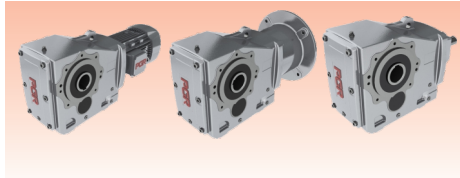

Gövdeden montajlı
Montierung am Gehäuse
Montaggio pendolare

8-11

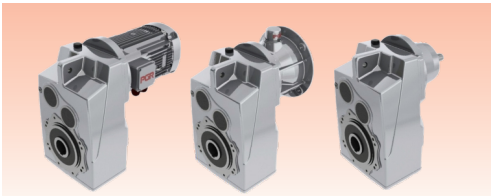

PD

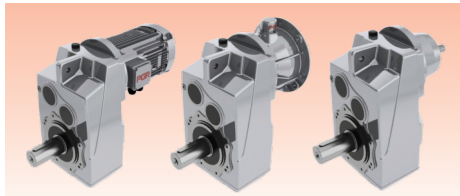

PM

12-15

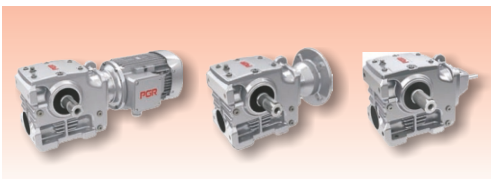

Ayaktan montajlı
Montierung mit Fussgehäuse
Montaggio con piedi

PSH

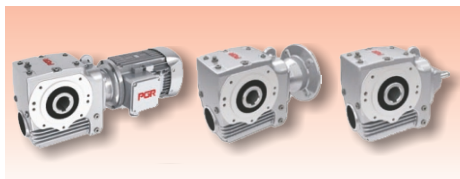

Gövdeden montajlı
Montierung am Gehäuse
Montaggio pendolare

16-18

Giriş gücü ve servis faktörü

Input power and service factor

Giriş gücü ve servis faktörü

Her bir uygulama için gerekli giriş gücü, hesaplama ile saptanır. Motor anma gücü (P), bu giriş gücünden sonra seçilir. Normal olarak, belirli uygulama özel çalışma koşullarına ait güvenlik faktörleri gözleneceği ve anma motor çıkış seviyeleri genellikle standart çıkış seviyesi aralığında olduğu için motorun anma gücü istenilen güçten biraz daha yüksektir.

Montaj yapılacak 3 fazlı bir AC motorun anma gücünü seçerken kısa dönem ve seyrek tork tesirini göz önüne almak gerekmez. Bir frekans inventörü üzerindeki 3 fazlı bir AC motor çalışırken ilave faktörler anma çıkış gücünün seçimini etkiler. Motorun aksine, kısa dönem ve seyrek tork tesiri önemli derecede dişli ünitesinin seçimini etkiler. Dişli ünitesi servis faktörü f_B bu kısa dönem ve seyrek tork tesirini ve ayrıca yeterli doğrulukla dişli ünitesi üzerinde etkileri göz önüne alır.

4. sayfadaki **diyagram 1** çalışma saatine veya güne bağlı olarak yük sınıflandırması, devir ve minimum servis faktörü arasındaki ilişkiyi sunmaktadır.

Input power and service factor

For every application requiring input power could be detected or determined by calculation. After determination input power, rated motor power (P) is defined. Motor power is greater than require input power due to safety factor is used according to operating conditions.

Selecting a motor type is important for right calculation for instance; three phase AC motor which is mounted to gear unit, affecting infrequent torque could not be considered but if you mount three-phase AC motor on frequency inverter latest available factor effects the output power. Besides of motor type short and infrequent torque impression effects selecting gear unit for that service factor is considered.

Diagram 1 which is shown below, presents relation between types of load, revolution per hour and minimum service factor depend on operation hours or day.

Diyagram - 1

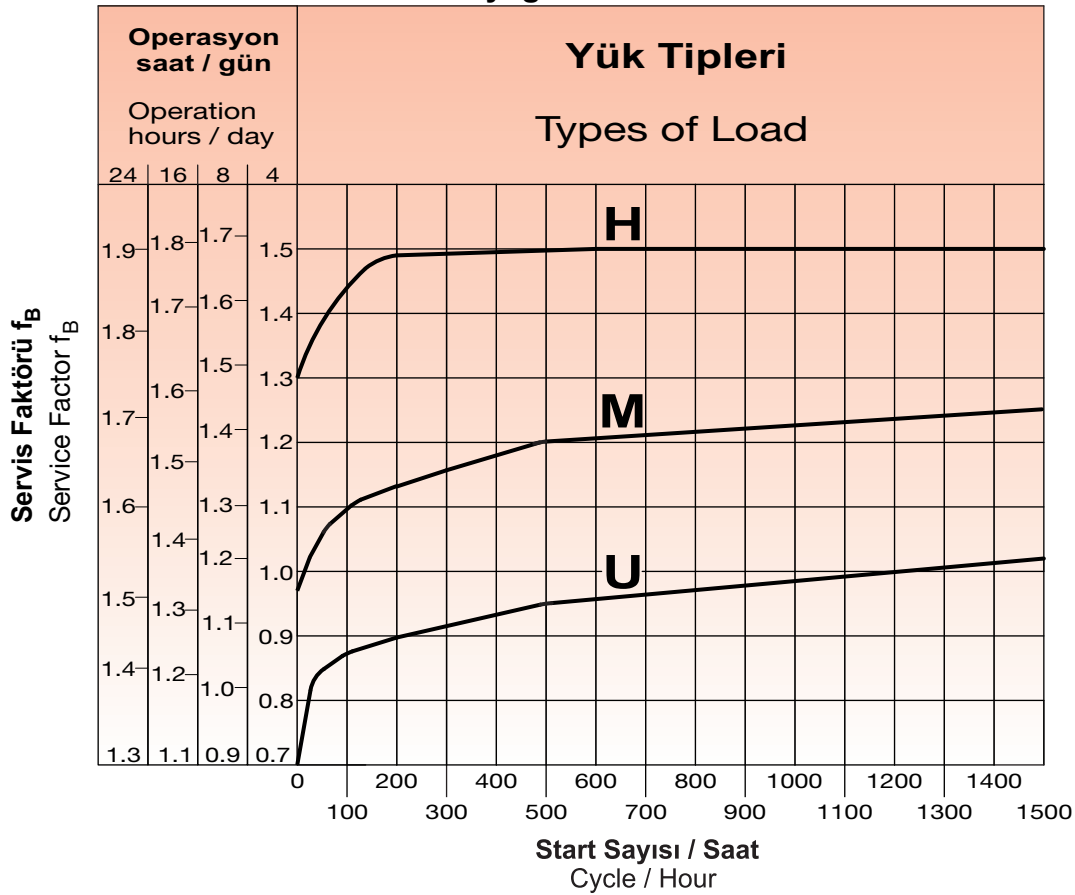

Diyagram 1, günlük çalışma zamanına bağlı gerekli minimum servis faktörü $f_{B \min}$ 'Z' saatteki çevrimleri, ve uygulama yükü sınıflandırması 'U', 'M', 'H' gösterir. Çalışma düzgünlüğüne ve kütle hız faktörüne bağlı olarak, üç yük sınıflandırması belirlenmiştir. Hareket ettiren makineden gelen etkiler çalışma düzgünlüğü sınıflandırmasında tanımlanırken, kütle hız faktörü en fazla olan yük üzerinde etkili olur.

Not : Elde edilen servis faktörü f_B kullanılan sürücü (tahrik) tipine göre "k" katsayısı ile çarpılır.

k = 1 ; elektrik motoru veya hidromotor,
k = 1.25 ; çok silindirli içten yanmalı motor,
k = 1.50 ; tek silindirli içten yanmalı motor

Diagram 1 shows requiring minimum service factor depend on revolution per hours 'Z' and types of load 'U', 'M' or 'H'. In following information mass acceleration factor will be explained how it effects to or relation between load classification. Forces or loads which are applied from driven machine to gear unit while determine load classification, mass acceleration factor is played important role on the high load classification which is designated with 'H' sign.

Note : Service factor f_B which is acquired from diagram should be modified with factor "k" that, depends on driver type.

k = 1 ; hydraulic motor and electrical motor
k = 1.25 ; multi-cylinder engine
k = 1.50 ; single-cylinder engine

Dişli Ünitesini Seçme (1/2)

Selecting a Gear Unit (1/2)

Dişli Ünitesini Seçme

Selecting a Gear Unit

Bir çalışmanın sınıflandırılması :

Operation classification;

a) Düzgün çalışma

Küçük karıştırıcılar, asansörler, konveyörler, montaj bantları, doldurma makineleri, bantlı konveyörler, temizleme makineleri, fanlar, test makineleri.

a) Uniform application

Small agitators, elevators, conveyors, assembly belts, filling machines, conveyor belts, cleaning machines, fans, testing machines.

b) Yumuşak şoklar, düzgün olmayan çalışma

Ağır konveyör bantları, değirmenler, ahır gübre makineleri, vinç hareketli mekanizmalar, bükme makineleri, çimento karıştırıcılar, dişli makineleri, ahşap işleme makineleri için sürücüler, vinçler, kayar kapılar, dengeleme makineleri.

b) Moderate shocks, non-uniform application

Heavy conveyors belts, mills, stall dunging machines, crane traveling mechanisms, bending machines, cement mixers, gear pumps, decoilers, tapping units, packaging machines, feed drives for wood processing machines, hoists, winches sliding doors, balancing machines.

c) Ağır şoklar, aşırı düzgün olmayan çalışma

Taş kırıcılar, eksantrik presler, doğrayıcılar, presler, taşlama milleri, çekiçli kırıcılar, kağıt öğütücüler, ağır karıştırıcılar, delme makineleri, katlama makineleri, dönen tezgahlar, yatay karıştırıcılar, kesiciler, vibratörler, santrifüj makineleri, döner tablalar.

c) Heavy shocks, extreme non-uniform application

Stone crusher, eccentric presses, choppers, presses, grinding mills, hammer mills, shredders, heavy mixers, punching machines, folding machines, rolling stands, tumbling barrels, shears, vibrators, centrifuges, roller tables.

Yük sınıflandırması, çalışma düzgünlüğünden ve aşağıdaki tabloya göre kütle hız faktörü 'm_{af}' den belirlenir. Burada, çalışma veya kütle hız faktöründen gelen daha yüksek sınıf yük sınıflandırmasında geçerlidir. (Örnek: aşırı düzgün olmayan çalışma ve m_{af} = 2,8 gibi durumda yük sınıfı 'H' olarak belirlenir.

Load classification is obtained from operation class and mass acceleration factor (m_{af}). For this reason in any situation which factor is greater than other you must take for calculation. (Eg; heavy - shock and m_{af} = 2,8 load classification must be 'H' .)

Yük Sınıfı	Çalışma	Kütle hız faktörü
U	Düzgün çalışma	m _{af} ≤ 0.25
M	Düzgün olmayan çalışma	0.25 < m _{af} ≤ 3
H	Aşırı düzgün olmayan çalışma	3 < m _{af} ≤ 10

Load Classification	Operation	Mass Acceleration Factor
U	Uniform application	m _{af} ≤ 0.25
M	Non-uniform application	0.25 < m _{af} ≤ 3
H	Extreme non-uniform application	3 < m _{af} ≤ 10

$$m_{af} = \frac{J_{ex.red}}{J_{mot}} = \frac{J_{ex}}{J_{mot}} \times \left(\frac{1}{i_{ges}} \right)^2$$

i_{ges} = Toplam dişli ünitesi oranı
J_{ex.red} = Hareket motoru üzerindeki azaltılmış tüm dış kütle atalet momenti
J_{ex} = Tüm dış kütle atalet momenti
J_{mot} = Motorun kütle atalet momenti

i_{ges} = Total gear unit ratio
J_{ex.red} = All external mass moment of inertia on the drive motor, reduced
J_{ex} = All external mass moment of inertia
J_{mot} = Mass moment of inertia of the motors

Kütle hız faktörü m_{af}, çıkış tarafındaki dış kütleler ile giriş tarafındaki yüksek hız kütlelerin arasındaki ilişkiyi gösterir. Kütle hız faktörü, başlatma ve frenleme işlemlerine ve titreşime göre dişli ünitesindeki tork tesir seviyesini önemli derecede etkiler. Örneğin; bantlı konveyör sistemlerinde dış kütle atalet momenti taşınan ürün kadar yük uygular. m_{af} > 10 ise, transfer elemanlarında büyük bir oynama, yük sınıflamasında belirsizlik varsa veya şüphedeyseniz, PGR'e danışınız.

Technically mass acceleration factor m_{af} mass different between external output-side and high speed input-side. m_{af} is played important role at the level of torque propulsive in the gear unit. It is mostly effected at start-up, braking operation and vibration. Please contact with PGR where m_{af} is greater than 10 and large play in transfer elements and vibration in the system.

Servis faktörü f_B, maksimum dişli ünitesi çıkış momenti M_{amax} ile montajlanmış motor gücü P, çıkış hızı n ve dişli ünitesi verimi () sonucu ortaya çıkan momenti M_a arasındaki ilişkidir.

Calculation of service factor is illuminated below. It depends on maximum output moment of gear unit and the output moment which is calculated from motor power, rotation speed and efficiency.

$$M_{af} = \frac{9550 \cdot P1}{n_2} \text{ [Nm]}$$

$$P1 \text{ [kW]}, n_2 \text{ [min}^{-1}]$$

$$f_B = \frac{M_{amax}}{M_a}$$

Dişli Ünitesini Seçme (2/2)

Selecting a Gear Unit (2/2)

$$P_T = \frac{M_a \cdot n_2}{9550} \text{ [kW]}$$

$$M_a \text{ [Nm]}, n_2 \text{ [min}^{-1} \text{]}$$

Dişli ünitesini doğru şekilde seçtiğinizde, çıkış ve hız genel açıklamalarından alınan servis faktörü f_B , diyagram 1'e göre minimum servis faktörü $f_{B \min}$ 'den büyük veya eşittir.

If the selecting gear unit is right, service factor which is taken from selection of gear motors table, must be greater than minimum service factor $f_{B \min}$ which is taken from diagram-1 (see page 4) according to types of load.

$$f_B \geq f_{B \min}$$

Helisel, parallel mil ve helisel konik dişli ünitelerinde herbir kademe için çok yüksek bir seviyede verimlilik vardır (herbir kademe için yaklaşık %98 veya $\eta = 0,98$). Bu yüzden hesaplamalarda verim $\eta = 1,0$ alınması yeterli doğru sonuçlara ulaşılmasına yardımcı olur. Helisel sonsuz dişliler ile ilgili dişli ünitesi verimliliği, herbir çıkış hızı n_2 'ye ait çıkış ve diş oran tablolarında listelenmiştir. W kovanı montajlı (serbest hareket mili) redüktörde çıkış gücü aşağıdaki formülden hesaplanır.

Efficiency is approximately 98 % at helical, helical bevel parallel shaft gear units. For that reason efficiency could be taken $\eta = 1$ it shows that efficiency does not effect the calculation. But, for helical worm gear efficiency is given at table which is depended on output speed and gear ratio.

With W cylinder (free drive shafts) ;

$$P_1 = \frac{M_{amax} \cdot n_2}{9550 \cdot f_{B \min}} \text{ [kW]}$$

$$M_{amax} \text{ [Nm]}, n_2 \text{ [min}^{-1} \text{]}$$

Burada, azami hareket gücü $P_{1 \max}$ aşılamaz.

Value which calculated from equation P_{11} must be less than $P_{1 \max}$ which is taken from the selection of W cylinder tables.

$$P_1 \leq P_{1 \max}$$

W ve IEC tipi redüktörler için performans tablosunda herbir çıkış devri n_2 , maksimum çıkış momenti M_{amax} , maksimum motor gücü $P_{1 \max}$ listelenmiştir.

$P_{1 \max}$ is shown at performance table for W cylinder (with free input shaft) and IEC adapter.

Hareketli tarafa fren bağlandığında, (frenli motorlar gibi) fren momenti de bir dişli ünitesini seçmede göz önüne alınmalıdır. Gezinti hareketleri, çember dişliler, döner tablolar, kapı hareketleri, karıştırıcılar ve yüzey havalandırıcı ile ilgili uygulamalarda sıkça karşılaşılan yüksek dış kütle atalet momentli ($m \geq 2$) kullanımlarda frenleme momentinin, seçilen anma momentinin 1,2 katını aşmamasını öneririz. Daha yüksek frenleme torkları kullanılacaksa, bu durum dişli ünitesini seçerken göz önünde bulundurulmalıdır. Lütfen PGR'e danışınız.

However in selecting gear units brake can be equipped optionally and it is attached to the shaft or solid. It must be considered because of break torque. Application which have high external mass moment of inertia such as $m_{af} > 2$. We suggest break torque does not overrun 1,2 times motor torque.

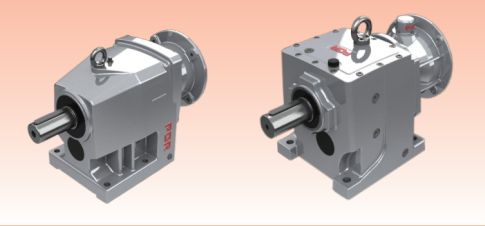
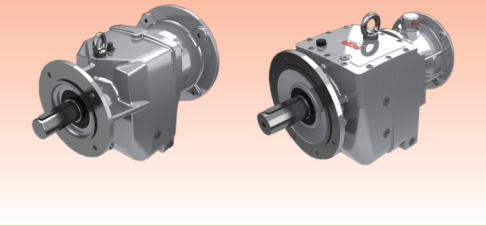
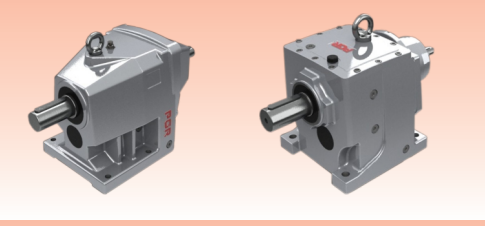
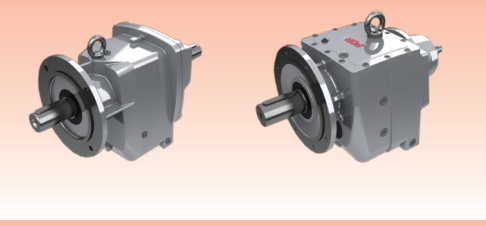
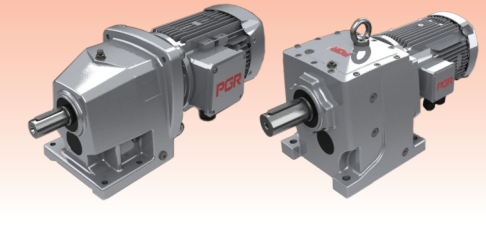
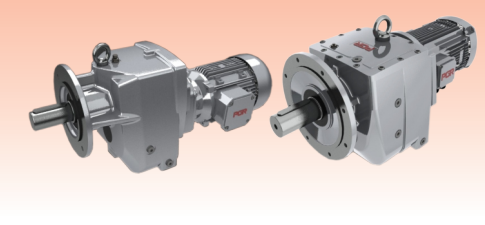
	PA	PF
Giris tipi / Antriebsart / Tipo entrata		
IEC Elektrik motor bağlantılı E-Motor direkt montiert Predisposto per motore elettrico		
W Motorsuz mil girişli Eingangswelle ohne Motor Albero entrata		
MOTOR Motorlu redüktör Getriebemotor Motoriduttore		

Giris devri / Antriebsdrehzahl / Giri entrata



Çıkis devri / Abtriebsdrehzahl / Giri uscita

$$n_2 = \frac{n_1}{i} \text{ (ratio)}$$



Seçim / Auswahl / Selezione per

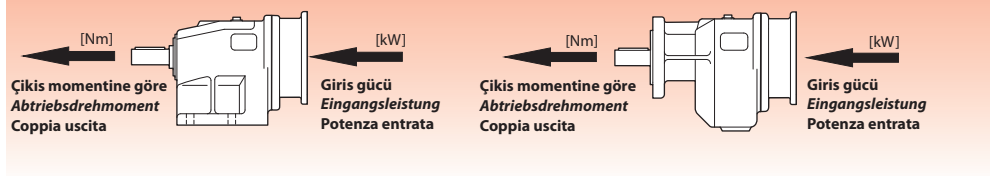

PA - PF

Montaj Özelligi / Befestigung / Fissaggio

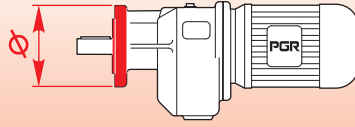

Mounting position / Einbaulage / Posizione di montaggio

M1

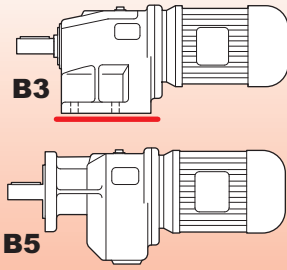

M2

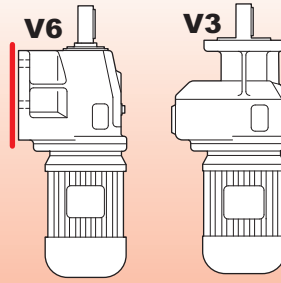

M3

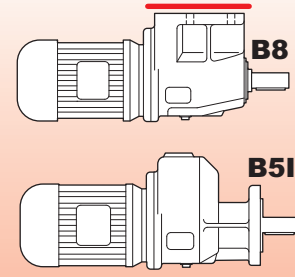

M4

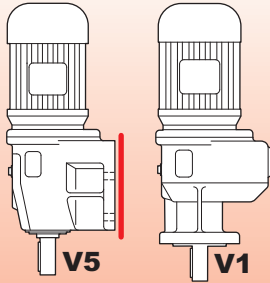

M5

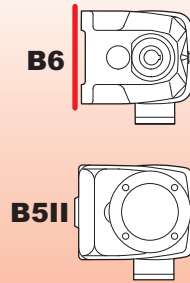

M6

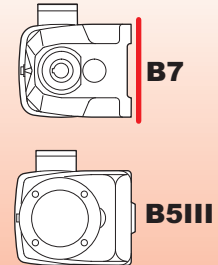

PA - PF

Terminal kutusu pozisyonu / Klemmenkastenposition / Posizione morsettiera

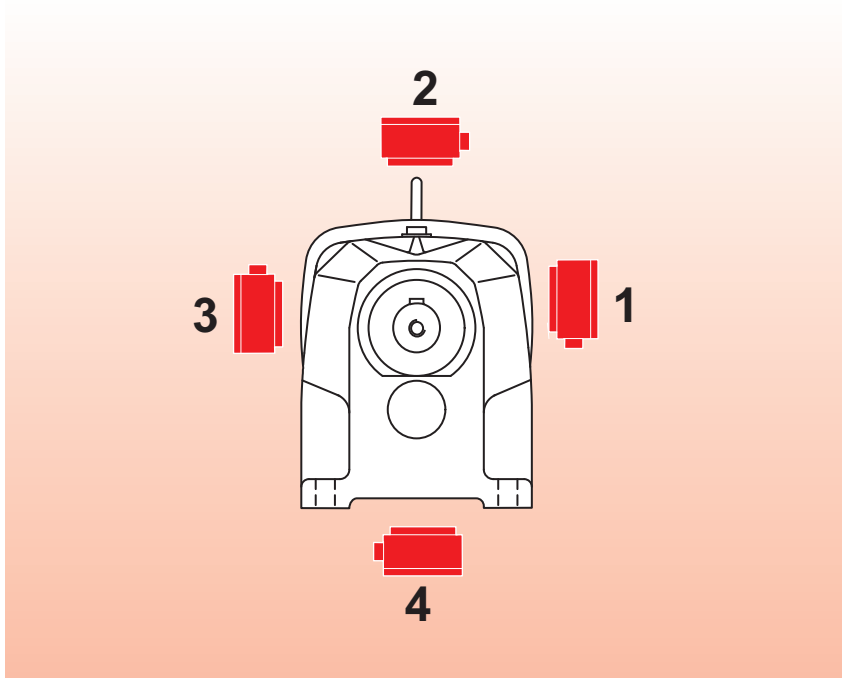

PKD

Giris tipi / Antriebsart / Tipo entrata

IEC

Elektrik motor bağlantılı
E-Motor direkt montiert
Predisposto per motore elettrico



W

Motorsuz mil girişli
Eingangswelle ohne Motor
Albero entrata



MOTOR

Motorlu redüktör
Getriebemotor
Motoriduttore



Giris devri / Antriebsdrehzahl / Giri entrata

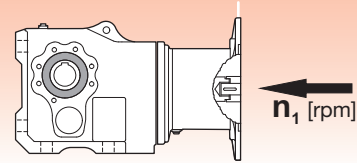

Çıkis devri / Abtriebsdrehzahl / Giri uscita

$$n_2 = \frac{n_1}{i \text{ (ratio)}}$$

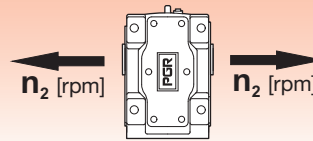

Seçim / Auswahl / Selezione per



PKD

Montaj Tipi /Montage / Montaggio

Ayaktan montajlı / Montierung mit Fussgehäuse / Montaggio con piedi

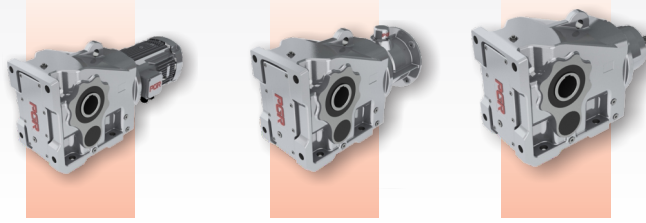

Montaj Özelliği /Befestigung / Fissaggio

DA

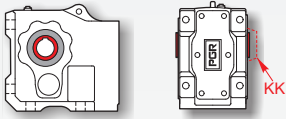

DA/Ç

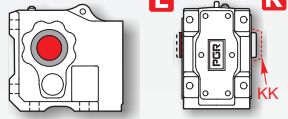

TMA

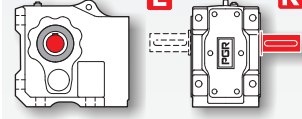

DA/B5

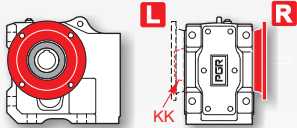

DA/B14

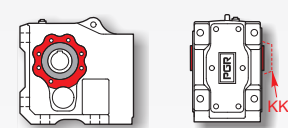

TMA/B5

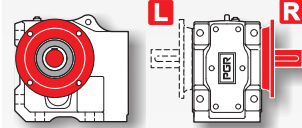

TMA/B14

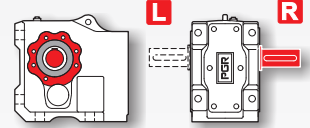

**DA/KS
DA/GKS**

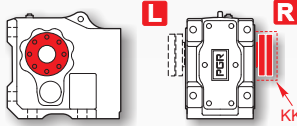

**DA/KS-B14
DA/GKS-B14**

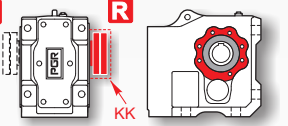

**DA/KS-B5
DA/GKS-B5**

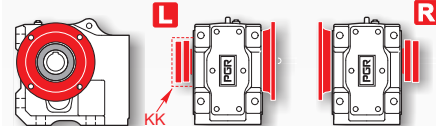

ÇMA

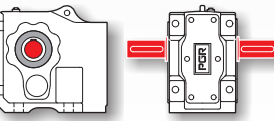

ÇMA/B14

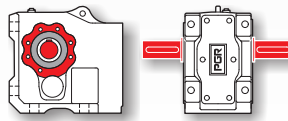

Mounting position / Einbaulage / Posizione di montaggio

M1

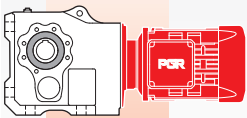

M2

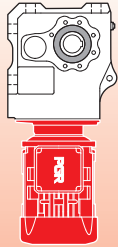

M3

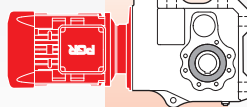

M4



M5

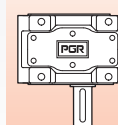

M6

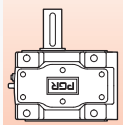

PKD

Montaj Tipi /Montage / Montaggio

Gövededen montajlı / Montierung am Gehäuse / Montaggio pendolare

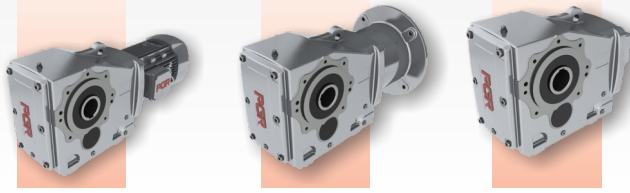

Montaj Özelligi /Befestigung / Fissaggio

DG/B5
DG/DIN5480-B5

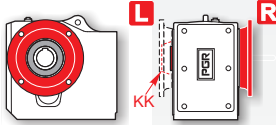

DG/B14
DG/DIN5480-B14

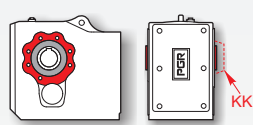

DG/Ç-B5

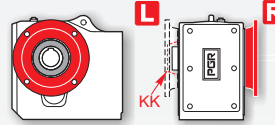

DG/Ç-B14

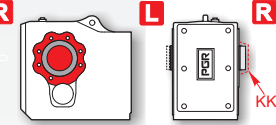

DG/KS-B5

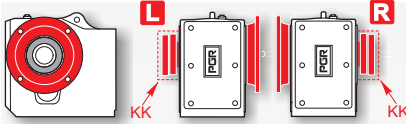

DG/KS-B14
DG/GKS-B14

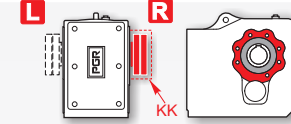

TMG/B5

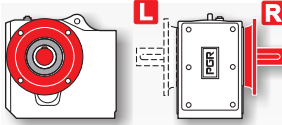

TMG/B14

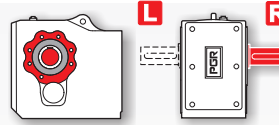

DG/TKP-B14

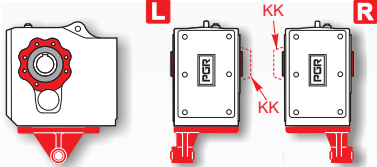

DG/KS-TKP-B14

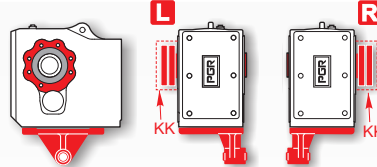

DG/TK

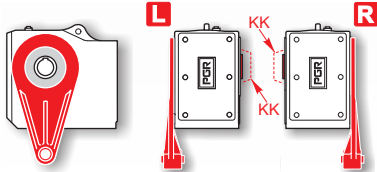

DG/KS-TK

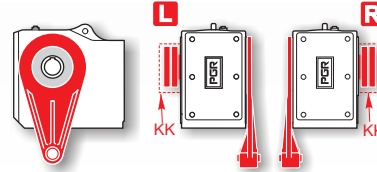

Mounting position / Einbaulage / Posizione di montaggio

M1

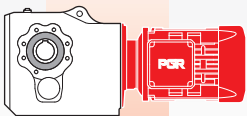

M2



M3

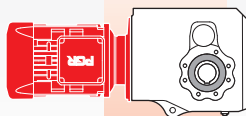

M4

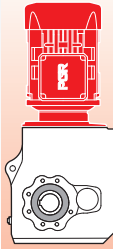

M5

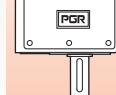

M6

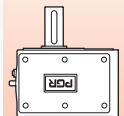

PKD

Terminal kutusu pozisyonu / Klemmenkastenposition / Posizione morsettiera

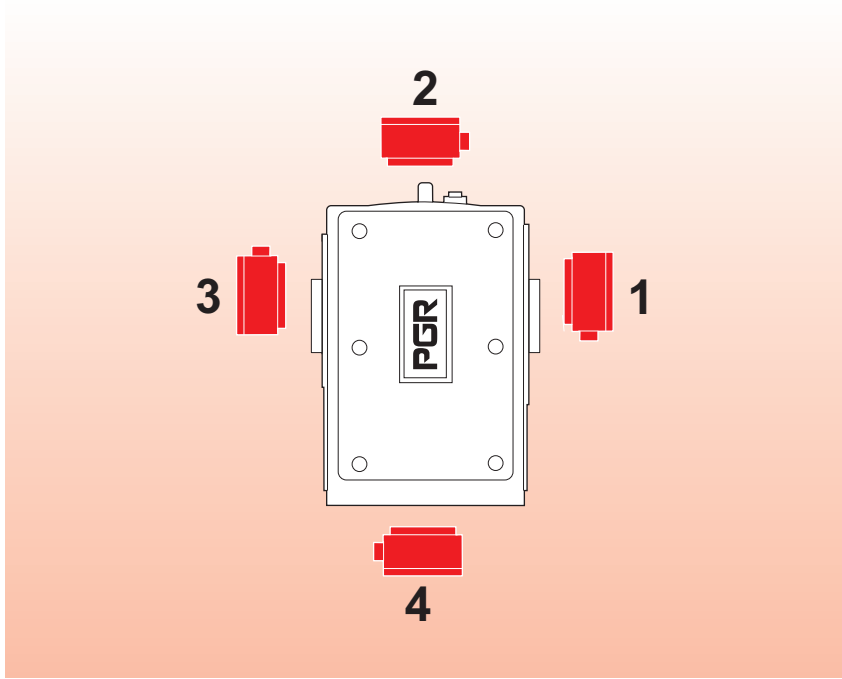

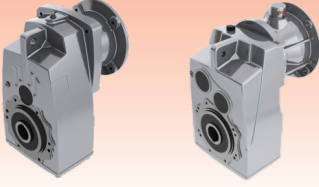
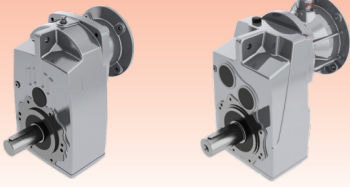
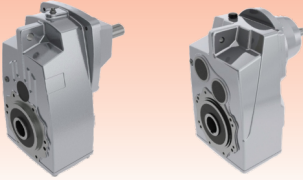
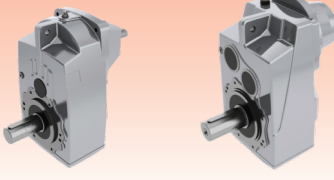
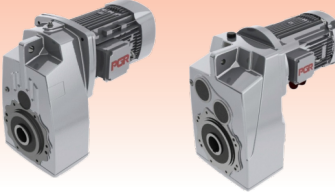
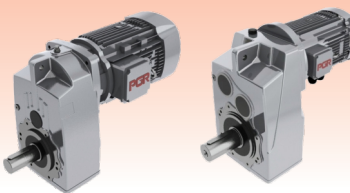
	PD	PM
Giris tipi / Antriebsart / Tipo entrata		
IEC Elektrik motor bağlantılı <i>E-Motor direkt montiert</i> Predisposto per motore elettrico		
W Motorsuz mil girisli <i>Eingangswelle ohne Motor</i> Albero entrata		
MOTOR Motorlu redüktör <i>Getriebemotor</i> Motoriduttore		

Giris devri / Antriebsdrehzahl / Giri entrata

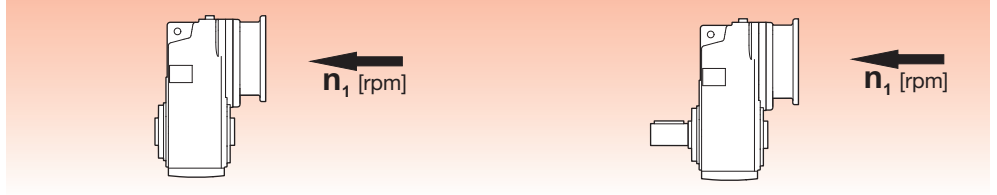

Çıkis devri / Abtriebsdrehzahl / Giri uscita

$$n_2 = \frac{n_1}{i \text{ (ratio)}}$$

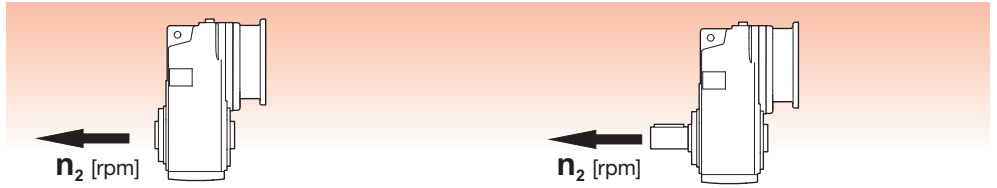

Seçim / Auswahl / Selezione per

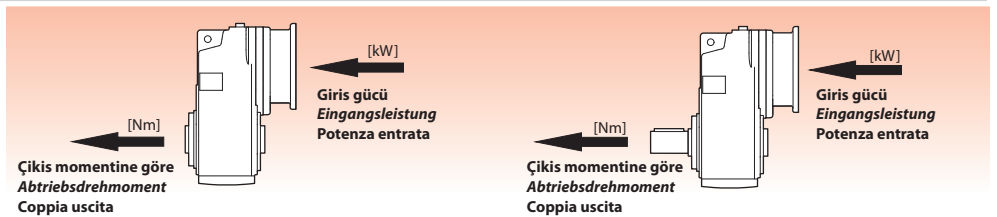

PD

Çikis Safti / Abtriebswelle / Albero uscita

PD.. —
PD.. DIN5480

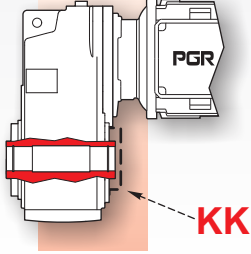

PD.. Ç

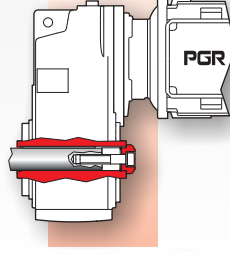

PD.. KS
PD.. GKS

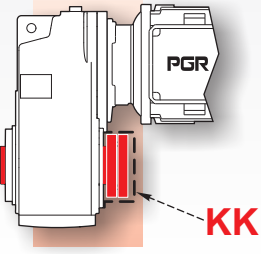

Montaj Özelliği / Befestigung / Fissaggio

—

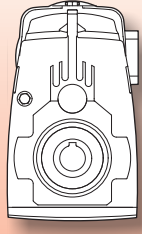

LT

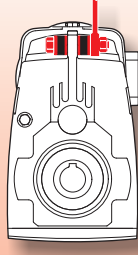

B5

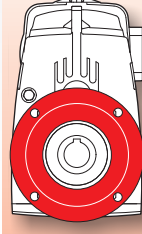

B14

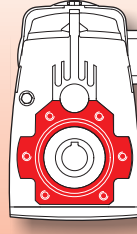

LT-B14

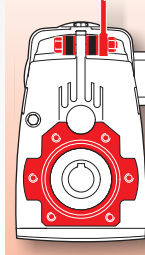

Flans / Flasch / Flangia uscita

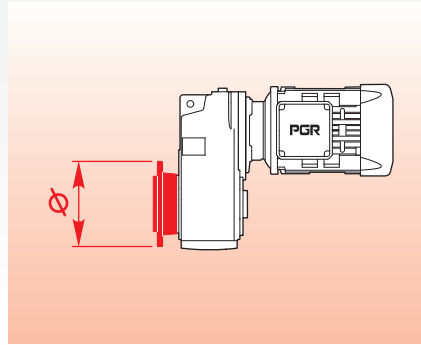

Mounting position / Einbaulage / Posizione di montaggio

M1
H1

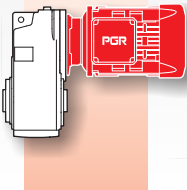

M2
H6

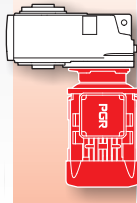

M3
H2

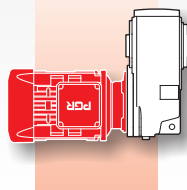

M4
H5

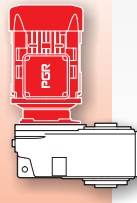

M5
H4

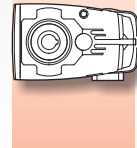

M6
H3

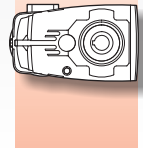

PM

Montaj Özelliği / Befestigung / Fissaggio

LT

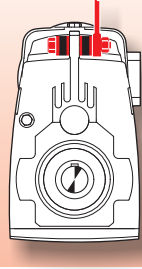

B5

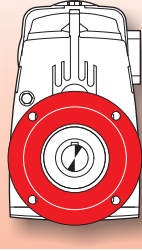

B14

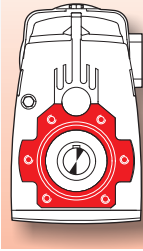

LT-B14

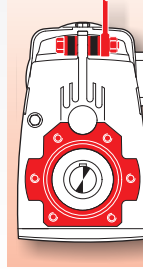

Flans / Flasch / Flangia uscita

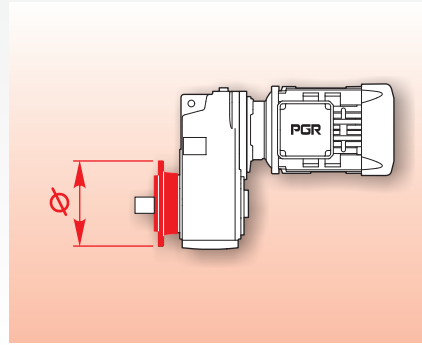

Mounting position / Einbaulage / Posizione di montaggio

M1
H1

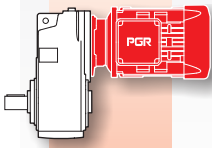

M2
H6

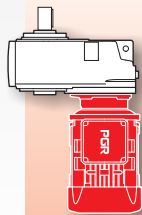

M3
H2

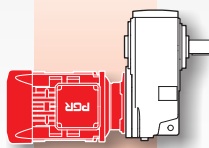

M4
H5

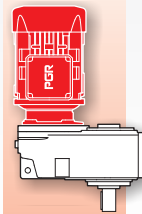

M5
H4

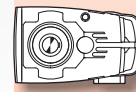

M6
H3

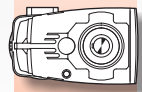

PD - PM

Terminal kutusu pozisyonu / Klemmenkastenposition / Posizione morsettiera

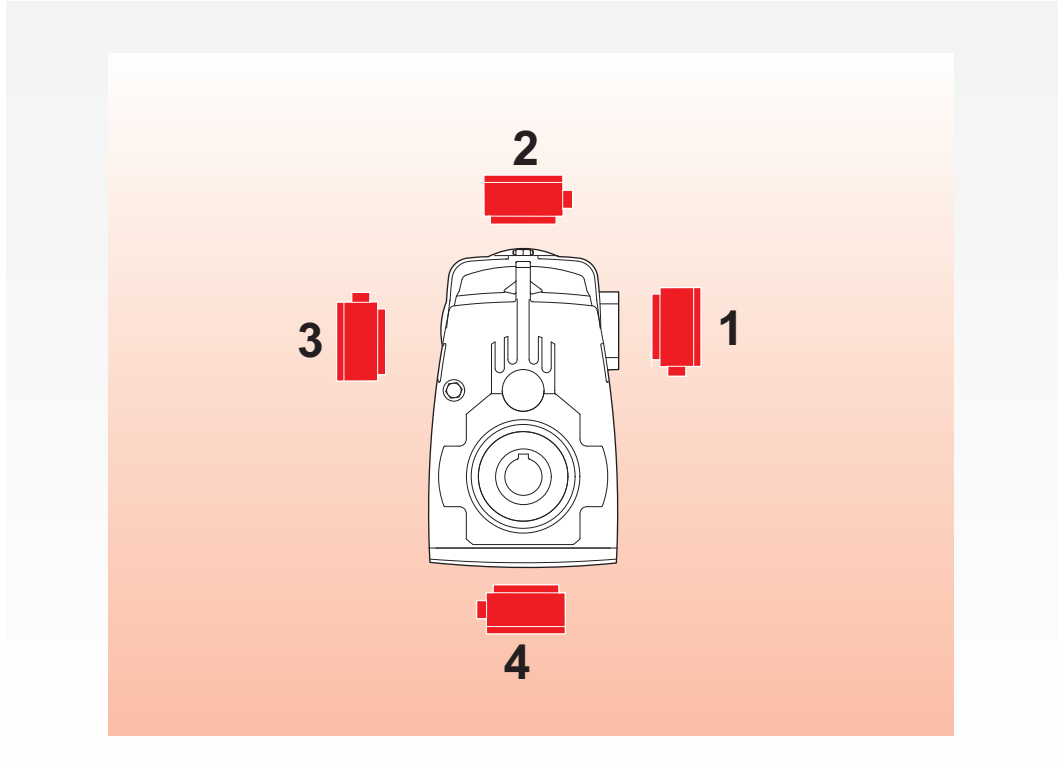

PSH

Giris tipi / Antriebsart / Tipo entrata

IEC

Elektrik motor bağlantılı
E-Motor direkt montiert
Predisposto per motore elettrico



W

Motorsuz mil girişli
Eingangswelle ohne Motor
Albero entrata



MOTOR

Motorlu redüktör
Getriebemotor
Motoriduttore



Giris devri / Antriebsdrehzahl / Giri entrata

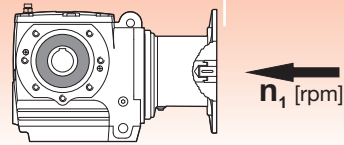

Çıkis devri / Abtriebsdrehzahl / Giri uscita

$$n_2 = \frac{n_1}{i \text{ (ratio)}}$$

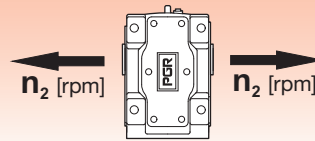

Seçim / Auswahl / Selezione per

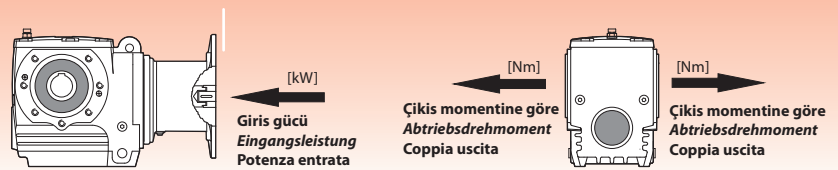

PSH

Montaj Tipi /Montage / Montaggio

**Gövdeden montajlı / Montierung am Gehäuse
Montaggio pendolare**



**Ayaktan montajlı / Montierung mit Fussgehäuse
Montaggio con piedi**

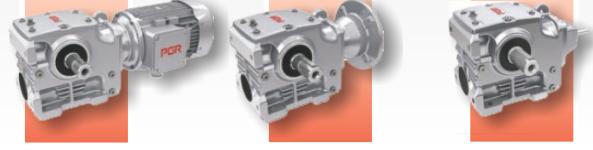

Montaj Özelliği /Befestigung / Fissaggio



TMA

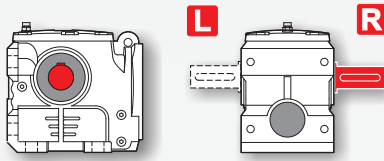

ÇMA

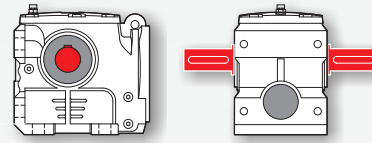

DG/B14

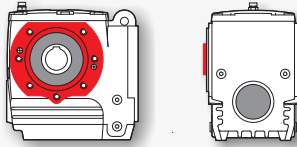

DG/B5

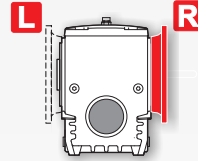

DG/Ç

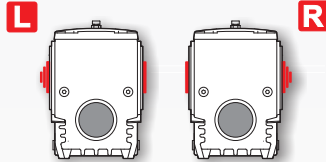

DG/Ç-KK

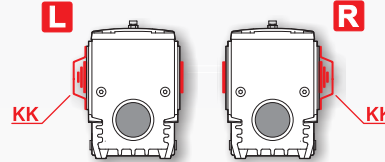

DG/KS

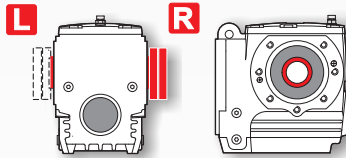

DG/KS-KK

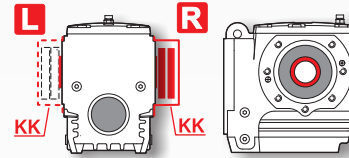

TMG/B5

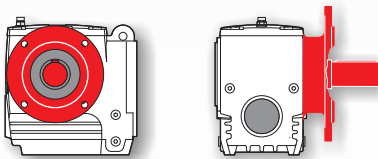

DG/TK

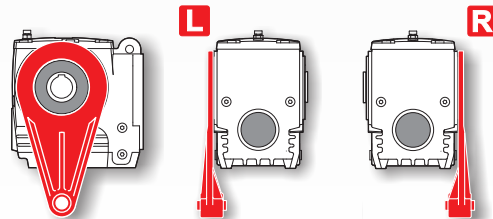

PSH

Mounting position / Einbaulage / Posizione di montaggio

M1

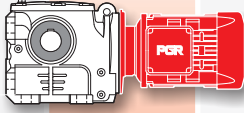

M2

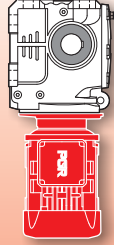

M3

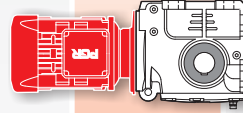

M4

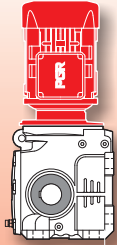

M5

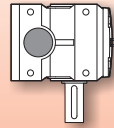

M6

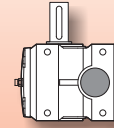

Terminal kutusu pozisyonu / Klemmenkastenposition / Posizione morsettiera

